



Expect Great Tools



NCG TOOLS INDUSTRY CO., LTD

Address : No.76-1, Shang Kuan Li, Yuanli Town , Miaoli Hsien, Taiwan, R.O.C. 358

TEL : 886-37-743060 (Rep.line) Fax : 886-37-743613. 743624

E-mail : ncg@ncgtools.com <http://www.ncgtools.com/>

NCG
TOOLS
THE RIVETING TOOL EXPERT





NCG Tools, founded in 1979, specializes in the design and manufacturing of fastening tool technologies such as riveters, rivet nut, rivet bolt, plastic rivet, and hollow wall anchor fastening tools.

We are constantly pushing ahead innovation in the field of fastening tools. Accompanying our innovations are our workmanship and quality. To ensure tight control of our manufacturing capabilities, our factory and manufacturing bases are 100% based in Taiwan.

Sam Lin



CATALOG

Air Hydraulic Riveter

SAR100 SHAR100	4
AR100 HAR100	5

Heavy Duty Multi-Function Fastening Tool

HF201 HF202 HF203 HF204 HF207	7
H1 H2 H3 H4 H7	8
HF151 HF152 LHF152 HF153 LHF153 HF154	9
HF101 HF102 LHF102 HF104 HF107 LHF107	10
TC151 TC152 TC153 TC154 TC157	11
TC101 TC102 TC103 TC104 TC107	12

Heavy Duty Multi-Function Swivel-Head Fastening Tool

H9-1 H9-2 H9-3 H9-4 H9-7	14
--------------------------------	----

Heavy Duty Riveter

TC51 H51	16
TC20	17

Hand Multi-Function Fastening Tool

S902 S903 S904 S905 S909	19
TC902 TC903 TC904 TC905 TC909	20
GN72 GN74 GN76	21
J703	22
S9BH03 S9BH05	23

Swivel-Head Hand Riveter

TC901 TN77 SN77	25
S201 S301 S401	26

Hand Riveter

GR11 GR12	28
TC701 J701 J705	29
TC702 TC722 GN71	30

Rivet Nut Fastening Tool

N701	32
------------	----

Hollow Wall Anchor And Plastic Rivet Fastening Tool

TC704 TC705	34
-------------------	----



Air Hydraulic Riveter



SAR100

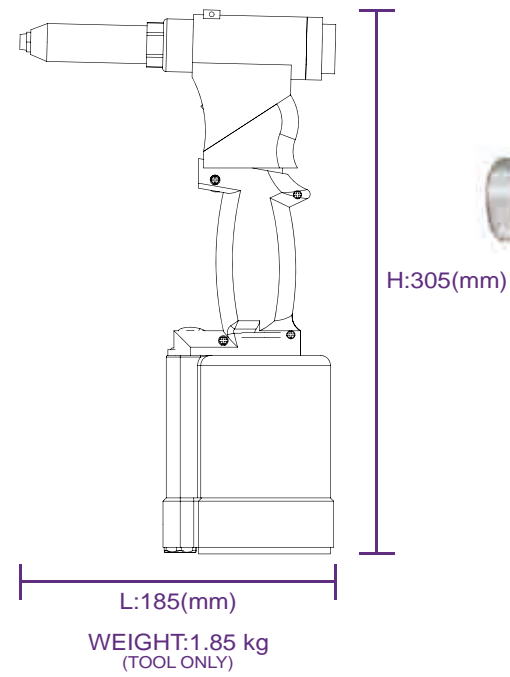

	SAR100	SHAR100
For FASTENER TYPE		
PRESSURE(bar)	5-6	5.5-6.5
STROKE LENGTH	16	19
POWER(kN)	9.6	15
RIVET RANGE	2.4-4.8mm (3/32"-3/16")	3.2-6.4MM (1/8"-1/4")

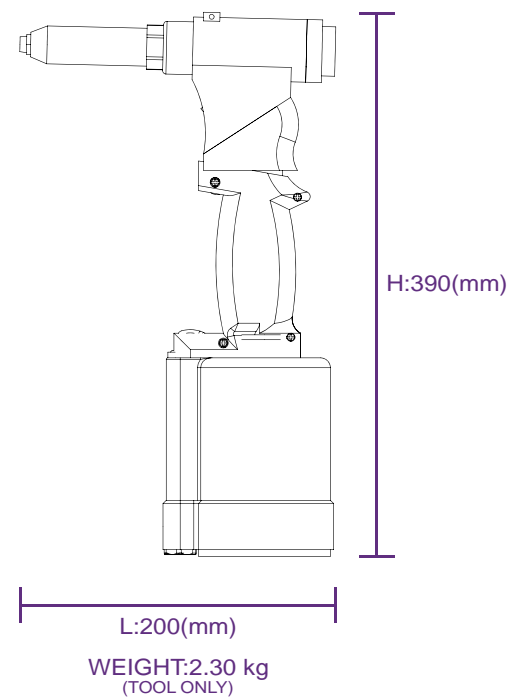

SHAR100

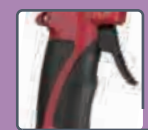



Comfortable rubberized grip.

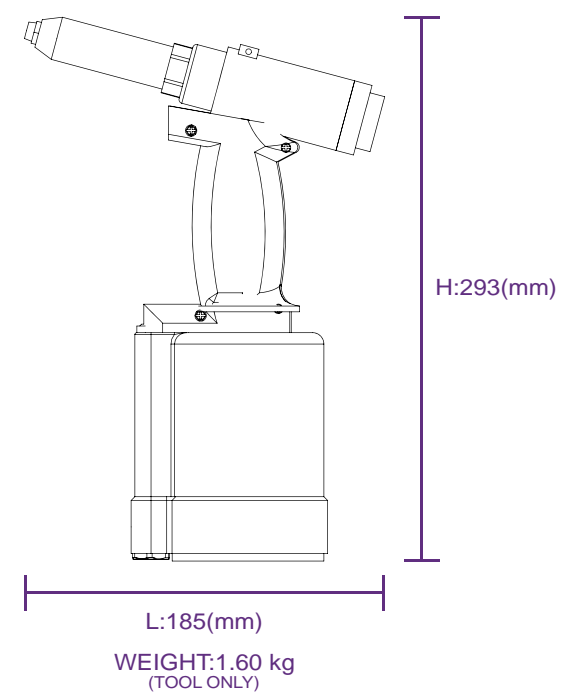

360° Swivel head for omni-directional Operation and easy positioning.

AR100



	AR100	HAR100
For FASTENER TYPE		
PRESSURE(bar)	5-6	5.5-6.5
STROKE LENGTH	16	19
POWER(kN)	9.6	15
RIVET RANGE	2.4-4.8mm (3/32"-3/16")	3.2-6.4MM (1/8"-1/4")

HAR100

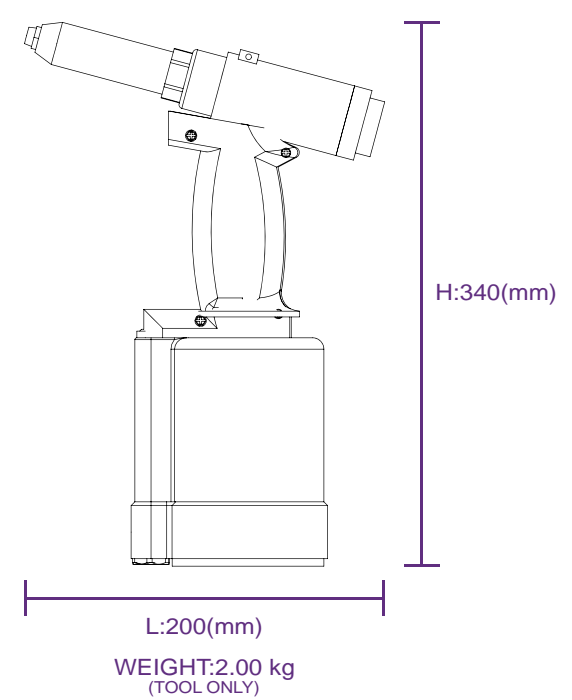

Comfortable rubberized grip.

Heavy Duty Multi-Function Fastening Tool





HF20x SERIES

Hx20 SERIES	HF201	HF202 LHF202*	HF203 LHF203*	HF204	HF207 LHF207*
For FASTENER TYPE					
BODY MATERIAL	ALUMINUM				
HANDLE MATERIAL	STEEL				
NOTE	Combination of HF201 and HF202			Combination of HF201, HF202 and HF204	
3.2-6.4mm (1/8"-1/4")	M4-M10 (#8-3/8")	*M4-M12 (#8-1/2")		M4-M8 (#8-5/16")	



Folding handles for easy storage and space saving.



All steel and aluminum construction.



Can be used with different types of fasteners by changing accessory.



Options available. Please see OPTIONS page.

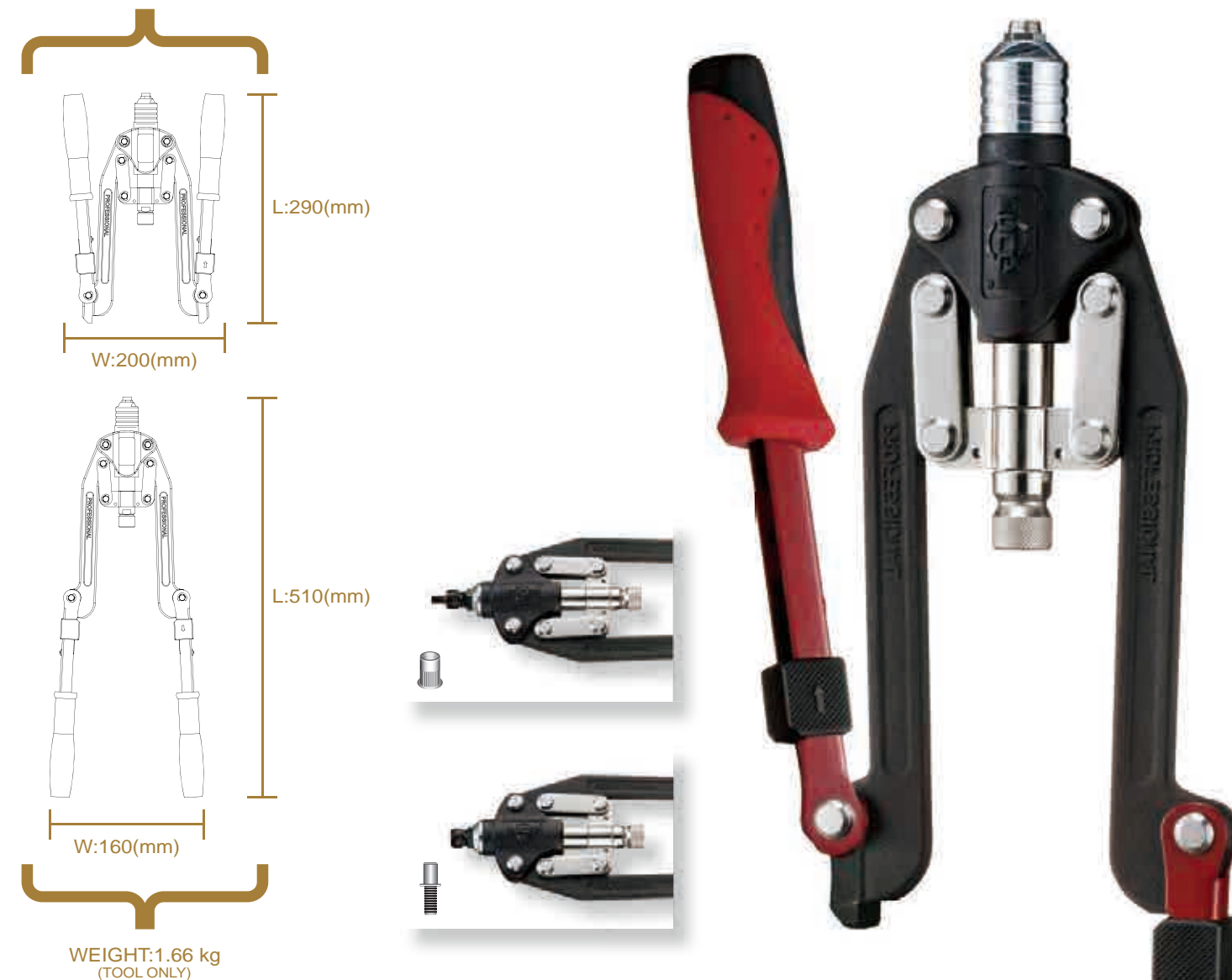

Hx SERIES

Hx SERIES	H1	H2	H3	H4	H7
For FASTENER TYPE					
BODY MATERIAL	ALUMINUM				
HANDLE MATERIAL	STEEL				
NOTE	Combination of H1 and H2			Combination of H1, H2 and H4	
3.2-6.4mm (1/8"-1/4")	M4-M10 (#8-3/8")	M4-M8 (#8-5/16")			



Folding handles for easy storage and space saving.



All steel and aluminum construction.



Can be used with different types of fasteners by changing accessory.



Options available. Please see OPTIONS page.

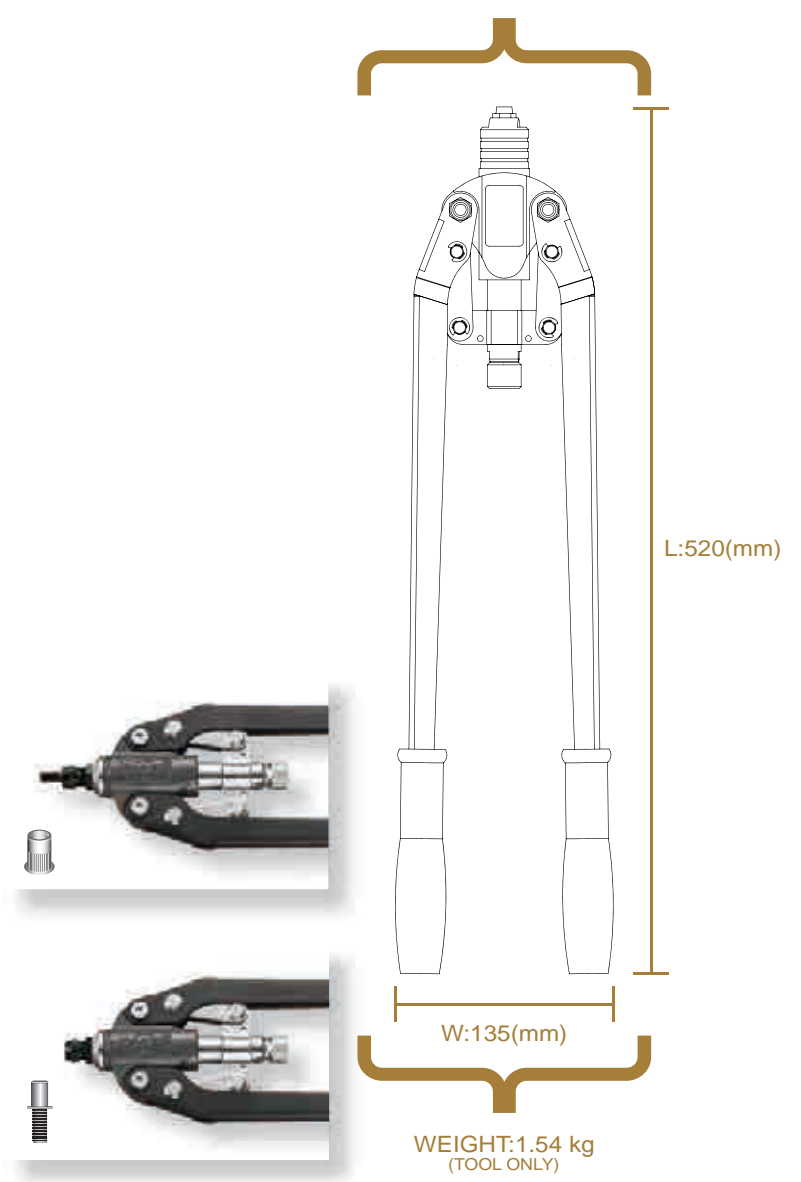

HF15x SERIES

HF15x SERIES	HF151	HF152 LHF152*	HF153 LHF153*	HF154	HF157 LHF157*
For FASTENER TYPE					
BODY MATERIAL	ALUMINUM				
HANDLE MATERIAL	STEEL				
NOTE	Combination of HF151 and HF152			Combination of HF151, HF152 and HF154	
	3.2-6.4mm(1/8"-1/4")	M4-M10 (#8-3/8")	*M4-M12 (#8-1/2") M4-M8(#8-5/16")		

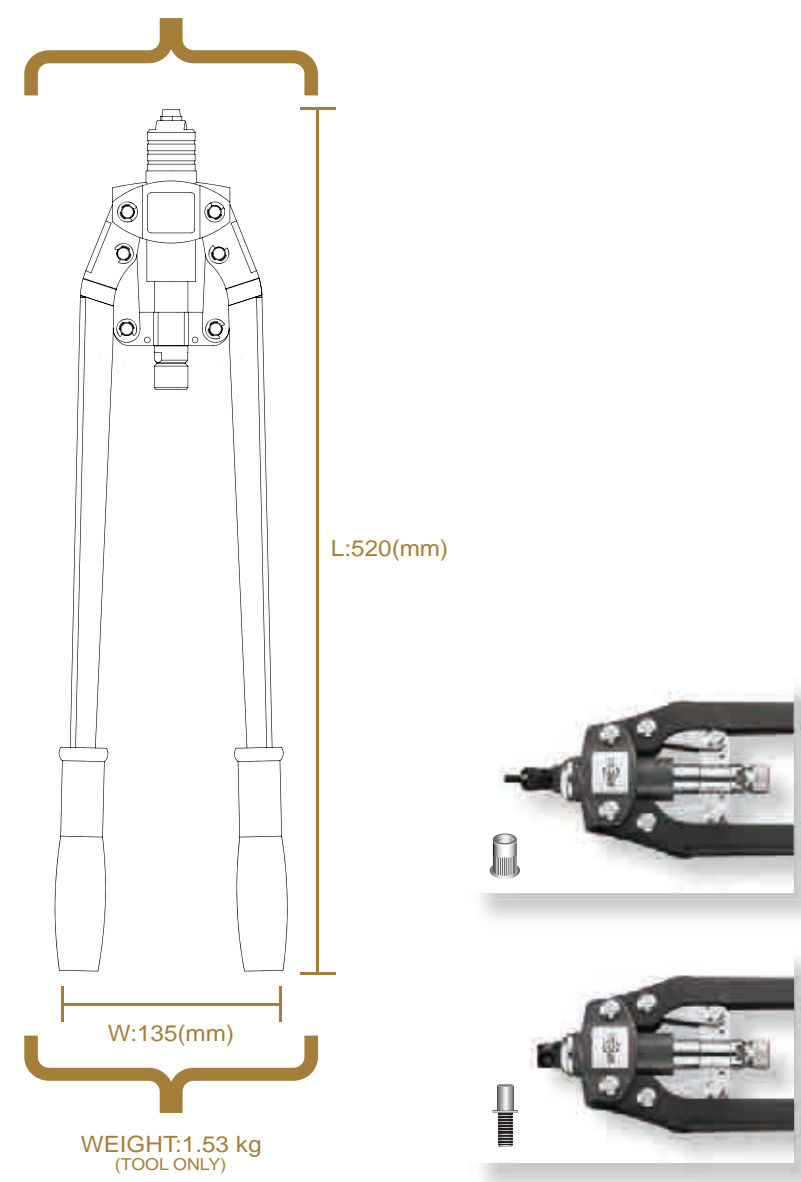

HF10x SERIES

HF10x SERIES	HF101	HF102 LHF102*	HF103 LHF103*	HF104	HF107 LHF107*
For FASTENER TYPE					
BODY MATERIAL	ALUMINUM				
HANDLE MATERIAL	STEEL				
NOTE	Combination of HF101 and HF102			Combination of HF101, HF102 and HF104	
	3.2-6.4mm(1/8"-1/4")	M4-M10 (#8-3/8")	*M4-M12 (#8-1/2") M4-M8(#8-5/16")		



All steel and aluminum construction.

Mult-Function Can be used with different types of fasteners by changing accessory.

Options available. Please see OPTIONS page.

All steel and aluminum construction.

Mult-Function Can be used with different types of fasteners by changing accessory.

Options available. Please see OPTIONS page.

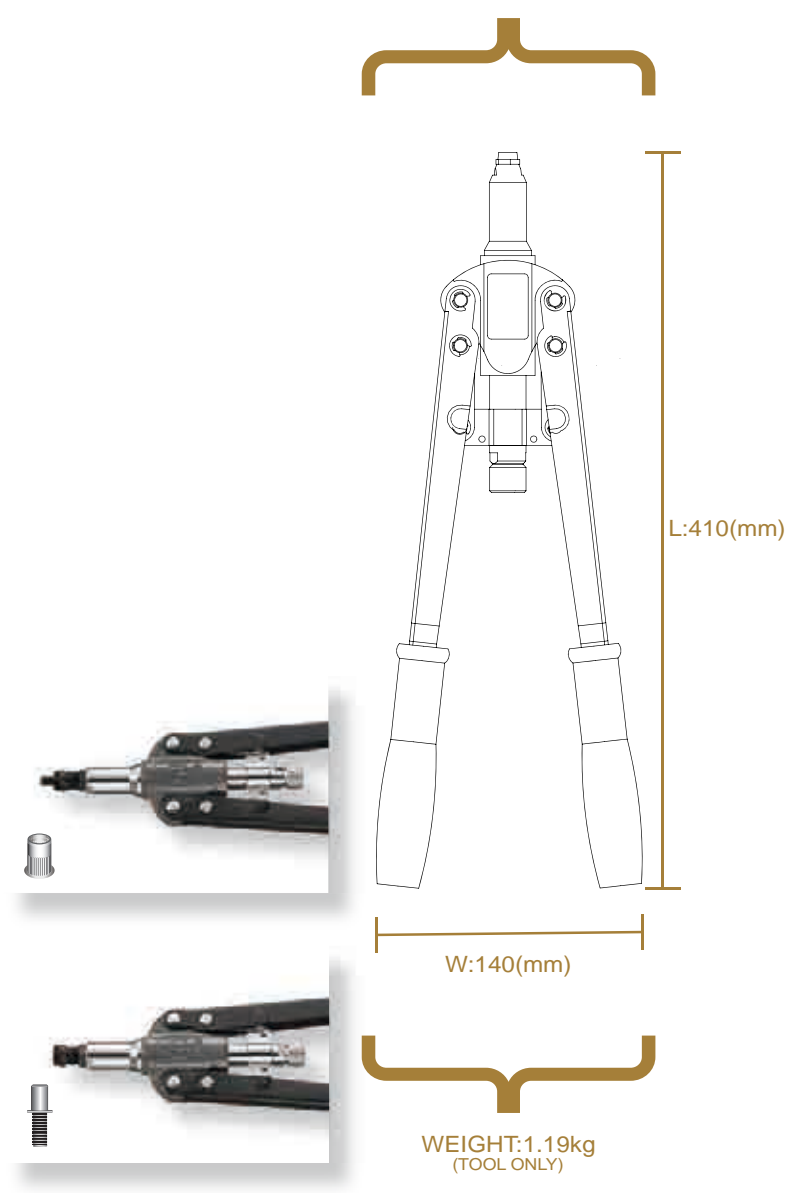

TC15x SERIES

TC15x SERIES	TC151	TC152	TC153	TC154	TC157
For FASTENER TYPE					
BODY MATERIAL	ALUMINUM				
HANDLE MATERIAL	STEEL				
NOTE	Combination of HF101 and HF102			Combination of HF101, HF102 and HF104	

2.4-4.8mm(3/32"-3/16")	M4-M8(#8-5/16")	M4-M8(#8-5/16")

All steel and aluminum construction.

Mult-Function
Can be used with different types of fasteners by changing accessory.

Options available. Please see OPTIONS page.

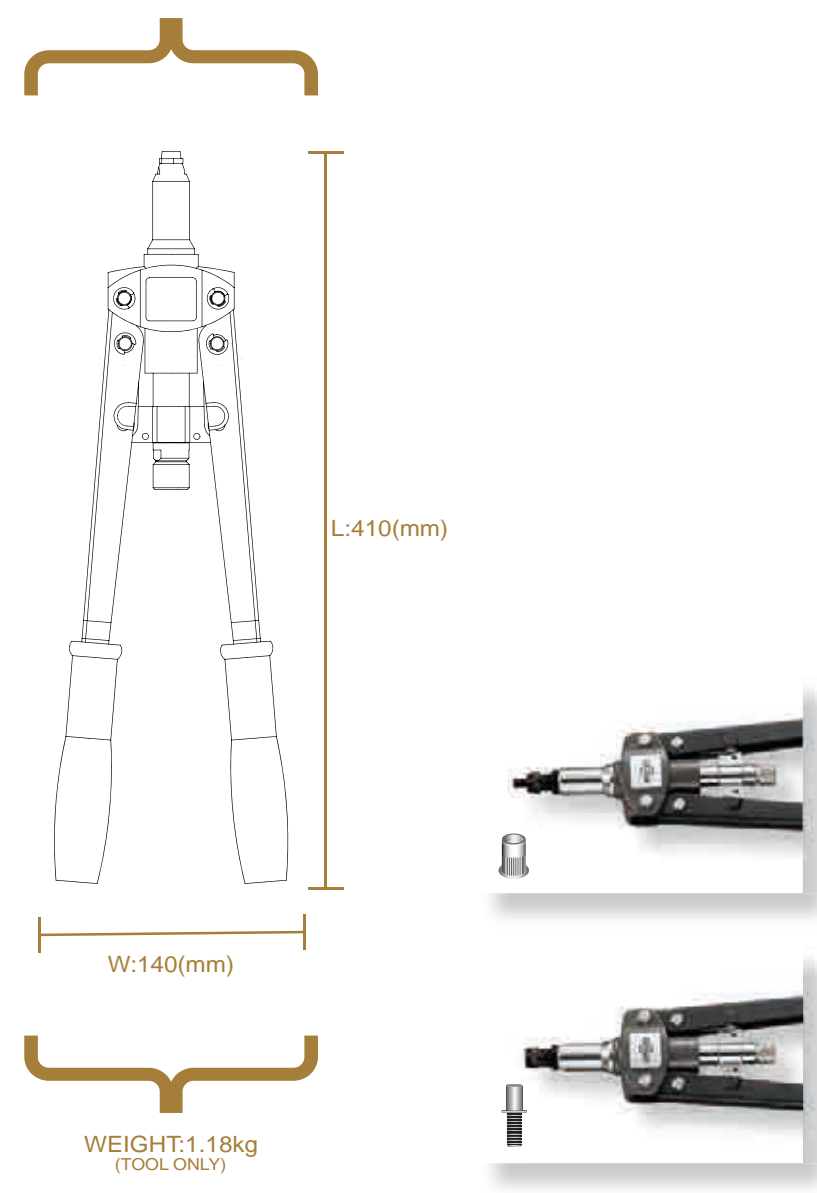

TC10x SERIES

TC15x SERIES	TC101	TC102	TC103	TC104	TC107
For FASTENER TYPE					
BODY MATERIAL	ALUMINUM				
HANDLE MATERIAL	STEEL				
NOTE	Combination of HF101 and HF102			Combination of HF101, HF102 and HF104	

2.4-4.8mm(3/32"-3/16")	M4-M8(#8-5/16")	M4-M8(#8-5/16")

All steel and aluminum construction.

Mult-Function
Can be used with different types of fasteners by changing accessory.

Options available. Please see OPTIONS page.



DRILL ATTACHMENT

AU100 SERIES

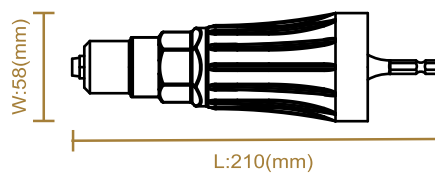

AU100 SERIES	AU101	AU102	AU103
--------------	-------	-------	-------

For FASTENER TYPE



Aluminum/Steel: 3.2-6.4mm (1/8"-1/4")

Stainless Steel (inox): 3.2-4.8mm (1/8"-3/16")

Aluminum/Steel: M4-M10 (#8-3/8")

Stainless Steel (inox): M4-M8 (#8-5/16")

Aluminum/Steel: M4-M8 (#8-5/16")

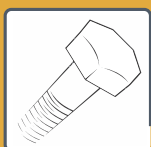

OMNI-MANDREL SYSTEM

Use regular screws as mandrels! Eliminates need for custom/special mandrels.

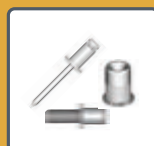

MULTI-FUNCTIONAL

Can be used with different types of fasteners by changing accessory.



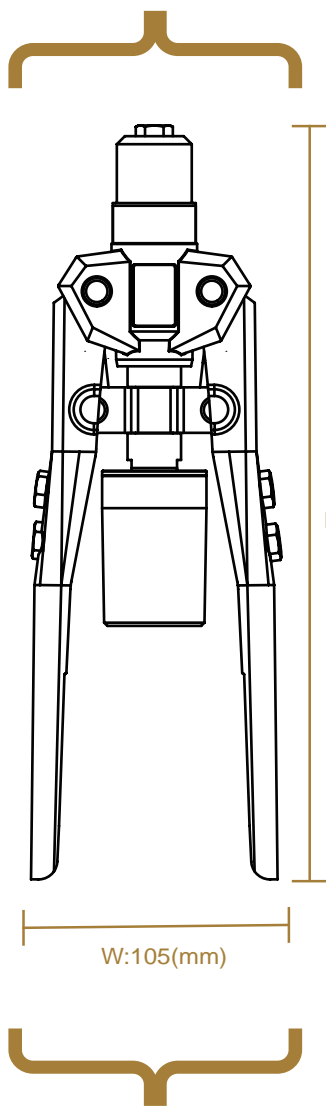



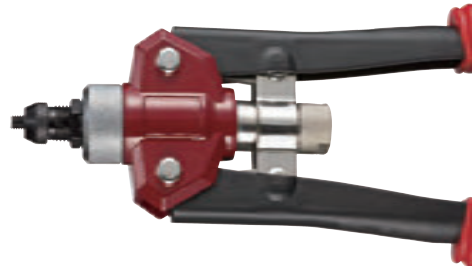
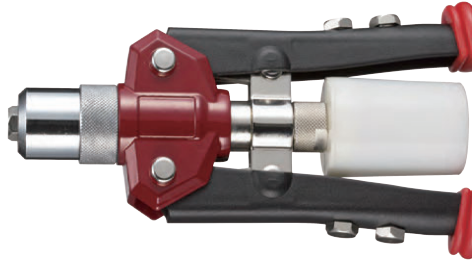

L:290(mm)

W:105(mm)

WEIGHT:1.18kg
(TOOL ONLY)



HF30x SERIES

HF30x SERIES	HF301	HF302	HF303	HF307
For FASTENER TYPE				
BODY MATERIAL	ALUMINUM			
HANDLE MATERIAL	STEEL			



Aluminum/Steel: 2.4-6.4mm (3/32"-1/4")
Stainless Steel (inox): 2.4-4.8mm (3/32"-3/16")

Aluminum/Steel: M4-M10 (#8-3/8")
Stainless Steel (inox): M4-M8 (#8-5/16")

Aluminum/Steel: M4-M8 (#8-5/16")

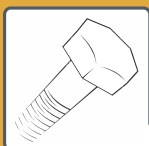

OMNI-MANDREL SYSTEM
Use regular screws as mandrels! Eliminates need for custom/special mandrels.



Can be used with different types of fasteners by changing accessory.

Heavy Duty Multi-Function Swivel-Head Fastening Tool

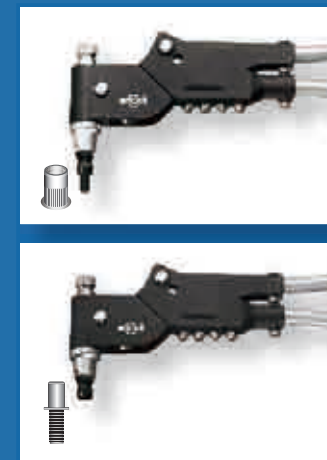
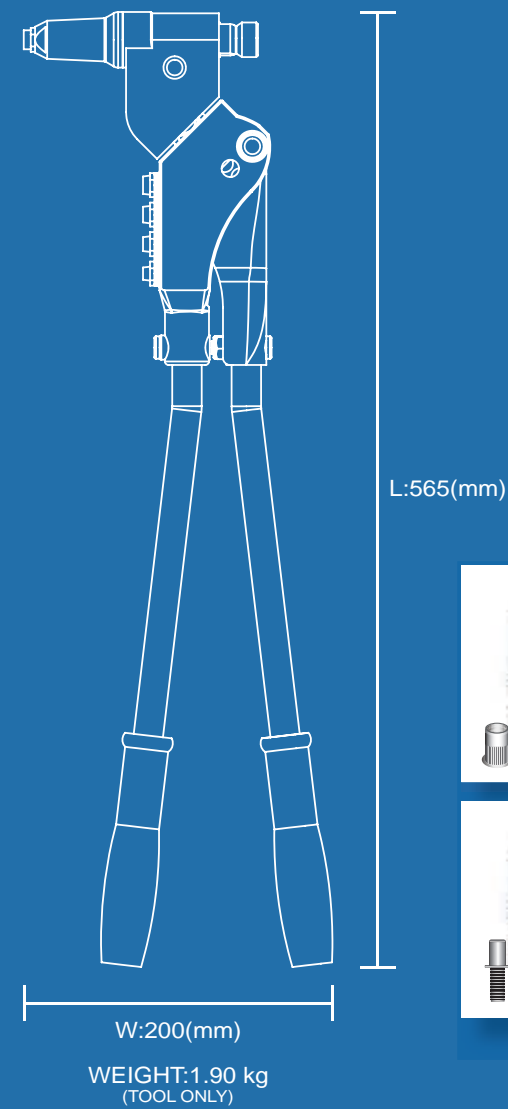

H9 Series

H9 SERIES	H9-1	H9-2	H9-3	H9-4	H9-7
For FASTENER TYPE					
BODY MATERIAL	ALUMINUM				
LEVER MATERIAL	STEEL				
NOTE			Combination of H9-1 and H9-2		Combination of H9-4, H9-2 and H9-4
	3.2-6.4mm(1/8"-1/4")	M4-M10(#8-3/8")			M4-M8(#8-5/16")



360° Swivel head for omni-directional operation and easy positioning.



All steel and aluminum construction.



Can be used with different types of fasteners by changing accessory.

Heavy Duty Riveter

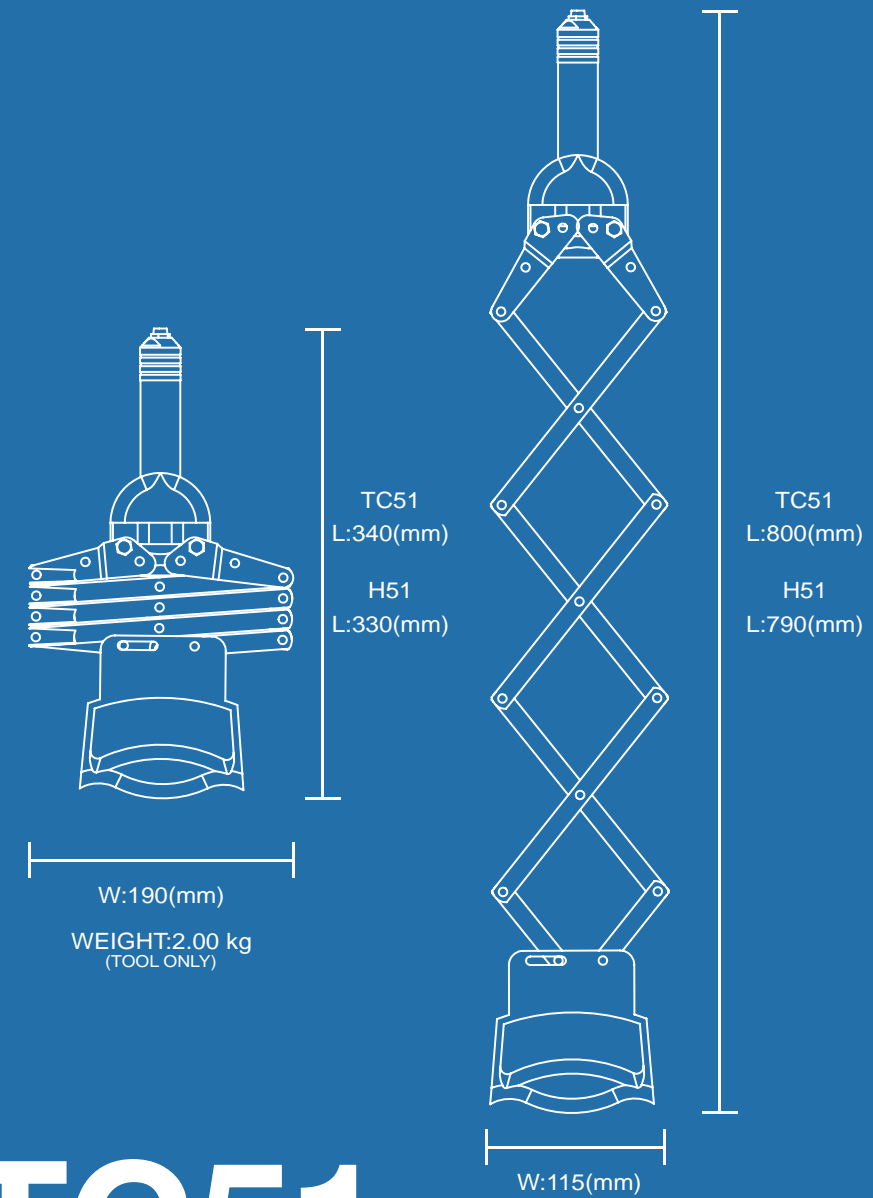

TC51 H51

H9 SERIES	TC51	H51
For FASTENER TYPE		
BODY MATERIAL	ALUMINUM	
LEVER MATERIAL	STEEL	
RIVET RANGE	2.4-4.8mm(3/32"-3/16")	3.2-6.4mm(1/8"-1/4")



All steel and aluminum construction.



Handle stabilizing design.

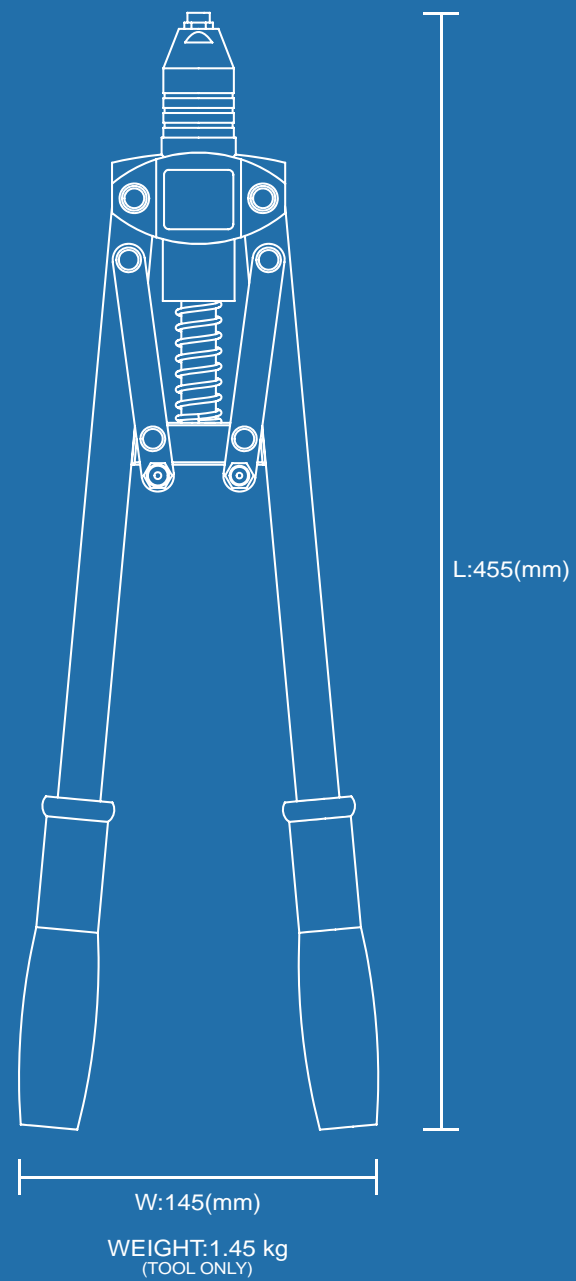

TC20

For FASTENER TYPE	
BODY MATERIAL	ALUMINUM
LEVER MATERIAL	STEEL
RIVET RANGE	2.4-4.8mm(3/32"-3/16")



All steel and aluminum construction.



Spring assisted design.

Hand Multi-Function Fastening Tool



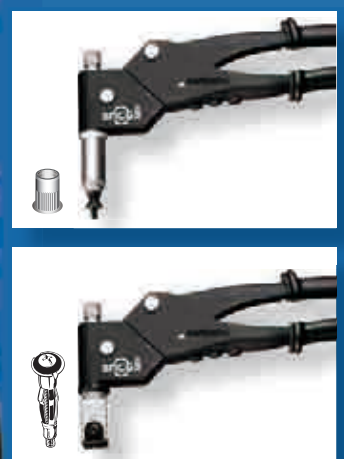
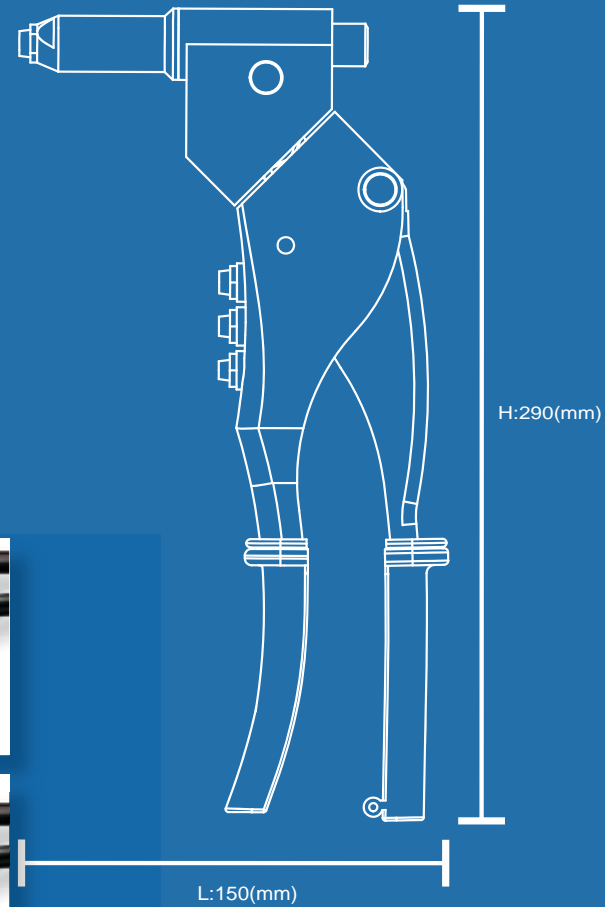

WEIGHT:0.90kg
(TOOL ONLY)

S90x Series

S90x Series	S902	S903	S904	S905	S909
For FASTENER TYPE					
BODY MATERIAL	ALUMINUM				
LEVER MATERIAL	STEEL				
NOTE			Combination of S902 and S903		Combination of S902, S903 and S904
	2.4-4.8mm(3/32"-3/16")	M3-M6(1/8"-1/4")	M3-M6(1/8"-1/4")		

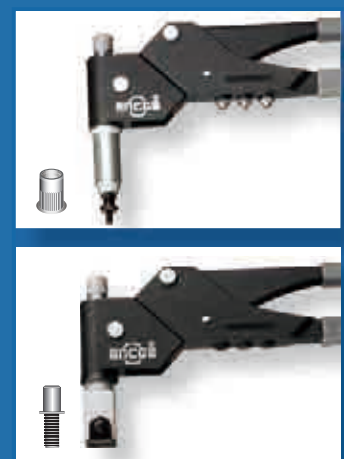
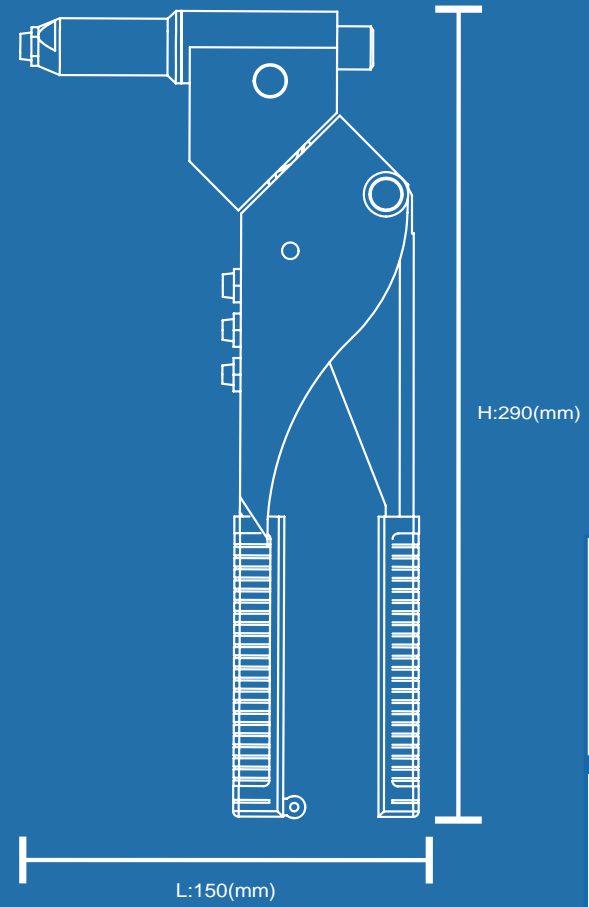

WEIGHT:0.90kg
(TOOL ONLY)

TC90x Series

TC90x Series	TC902	TC903	TC904	TC905	TC909
For FASTENER TYPE					
BODY MATERIAL	ALUMINUM				
LEVER MATERIAL	STEEL				
NOTE			Combination of TC902 and TC903		Combination of TC902, TC903 and TC904
	2.4-4.8mm(3/32"-3/16")	M3-M6(1/8"-1/4")	M3-M6(1/8"-1/4")		

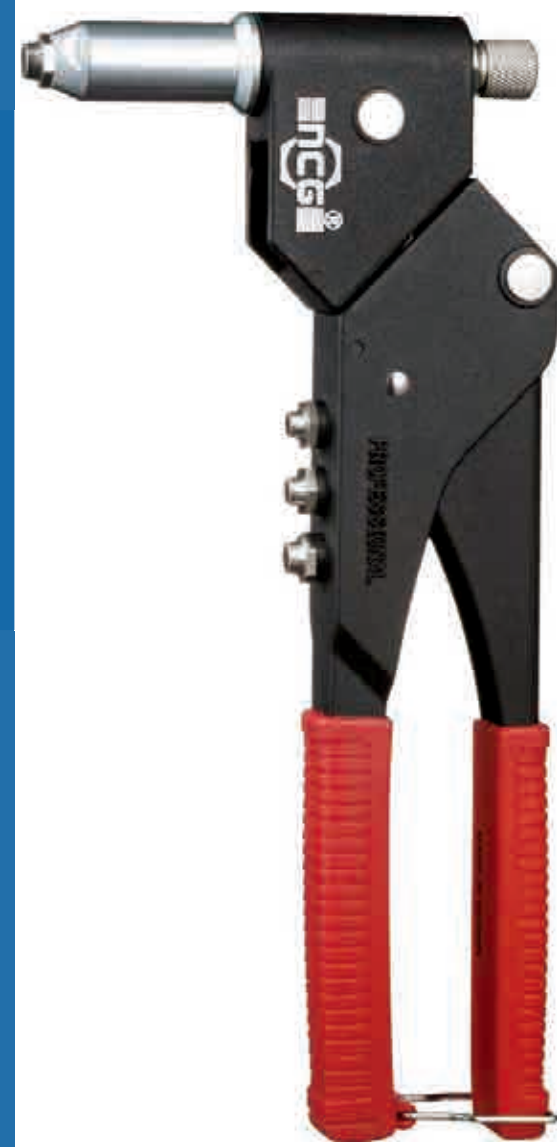

360° Swivel head for omni-directional Operation and easy positioning.

All steel and aluminum construction.

Multi-Function Can be used with different types of fasteners by changing accessory.

360° Swivel head for omni-directional Operation and easy positioning.

All steel and aluminum construction.

Multi-Function Can be used with different types of fasteners by changing accessory.

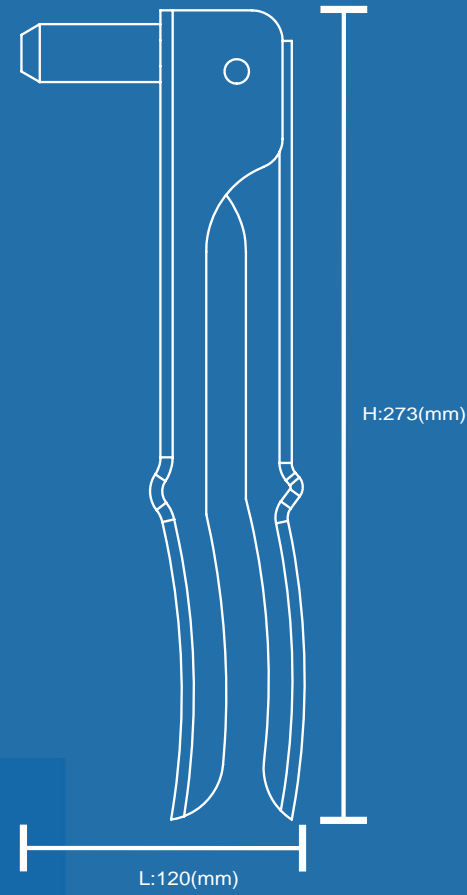

WEIGHT:0.80kg
(TOOL ONLY)

GN7x Series

T90x Series	GN72	GN74	GN76
For FASTENER TYPE			
BODY MATERIAL	ALUMINUM		
LEVER MATERIAL	STEEL		
NOTE	Combination of GN72 and GN74		
	M3-M6(1/8"-1/4")	M4-M6 (#8~1/4")	

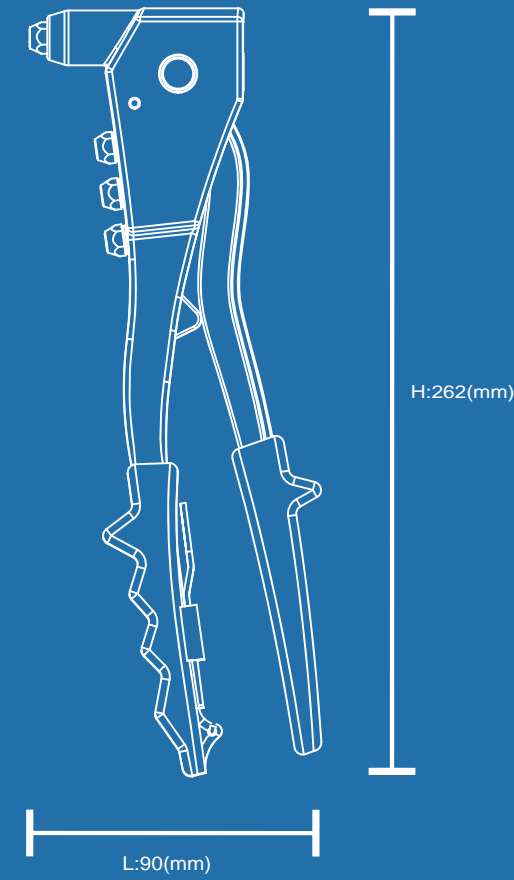

WEIGHT:0.56kg
(TOOL ONLY)

J703

J703		
For FASTENER TYPE		
BODY MATERIAL	ALUMINUM	
LEVER MATERIAL	STEEL	
	2.4-4.8mm(3/32"-3/16")	M3-M6(1/8"-1/4")



All steel and aluminum construction.



Can be used with different types of fasteners by changing accessory.



All steel and aluminum construction.



Can be used with different types of fasteners by changing accessory.

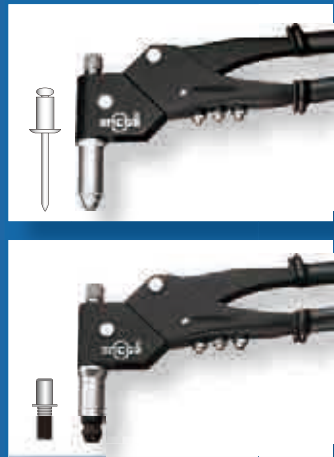
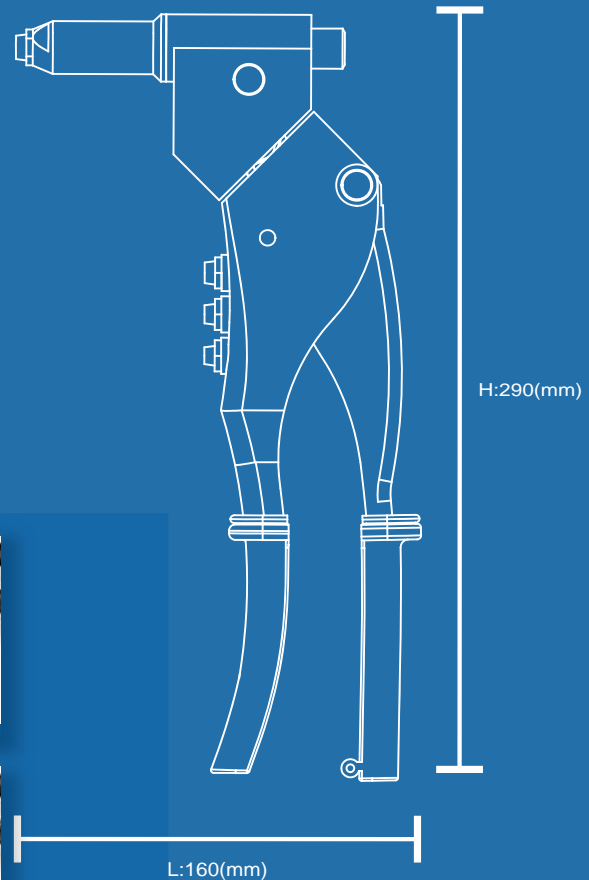

WEIGHT:0.90kg
(TOOL ONLY)

S9BH0x Series

	S9BH03	S9BH05
For FASTENER TYPE		
BODY MATERIAL	ALUMINUM	
LEVER MATERIAL	STEEL	
NOTE		
	2.4-4.8mm(3/32"-3/16")	M3-M6(1/8"-1/4")
		M4-M6 (#8-1/4")

Swivel-Head Hand Riveter



360° Swivel head for omni-directional Operation and easy positioning.



360° Swivel head for omni-directional Operation and easy positioning.



All steel and aluminum construction.



Can be used with different types of fasteners by changing accessory.



TC901 TN77 SN77

S201 S301 S401

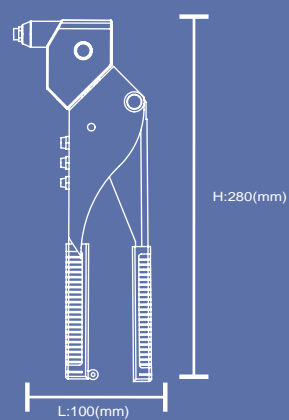

WEIGHT:0.75kg
(TOOL ONLY)

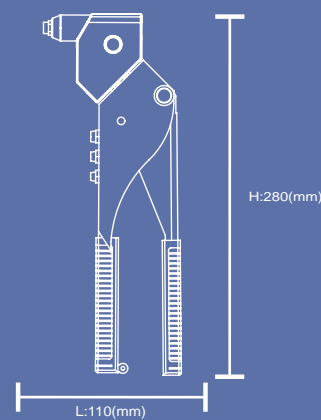

WEIGHT:0.75kg
(TOOL ONLY)

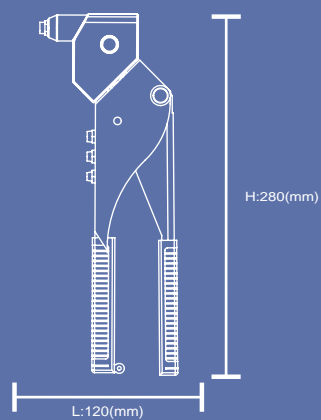

WEIGHT:0.75kg
(TOOL ONLY)

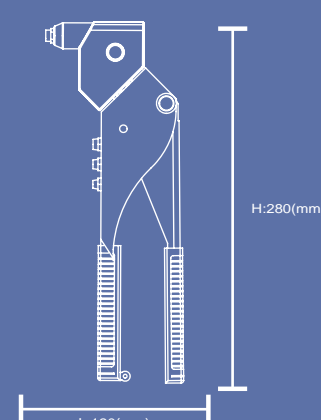

WEIGHT:0.75kg
(TOOL ONLY)

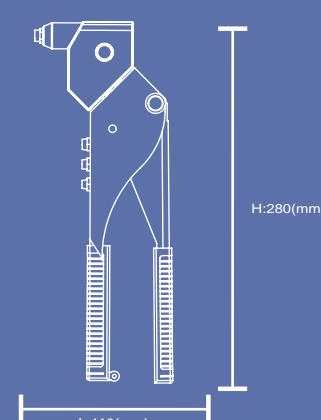

WEIGHT:0.75kg
(TOOL ONLY)

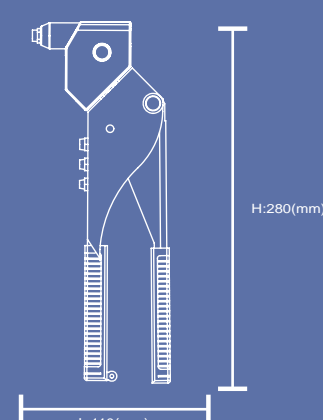

WEIGHT:0.75kg
(TOOL ONLY)

TC901

TN77

SN77

For FASTENER TYPE



BODY MATERIAL
LEVER MATERIAL
RIVET RANGE

ALUMINUM
STEEL
2.4-4.8mm(3/32"-3/16")

S201

S301

S401

For FASTENER TYPE



BODY MATERIAL
LEVER MATERIAL
NOTE

ALUMINUM
STEEL
2.4-4.8mm(3/32"-3/16")



360° Swivel head for omni-directional Operation and easy positioning.



All steel and aluminum construction.



360° Swivel head for omni-directional Operation and easy positioning.



All steel and aluminum construction.

Hand Riveter



GR11

GR12

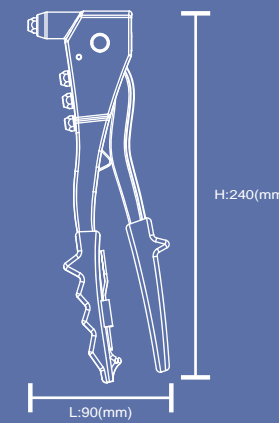

WEIGHT:0.42kg
(TOOL ONLY)

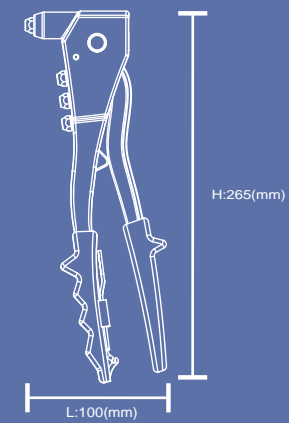

WEIGHT:0.62kg
(TOOL ONLY)

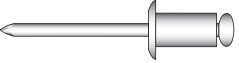
	GR11	GR12
For FASTENER TYPE		
BODY MATERIAL	ALUMINUM	
LEVER MATERIAL	STEEL	
RIVET RANGE	2.4-4.8mm(3/32"-3/16")	



All steel and aluminum construction.



Strong aluminum body frame.



TC701 J701 J705

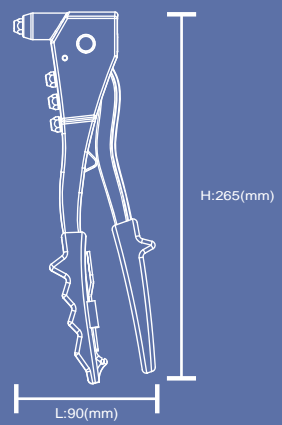

WEIGHT:0.55kg
(TOOL ONLY)

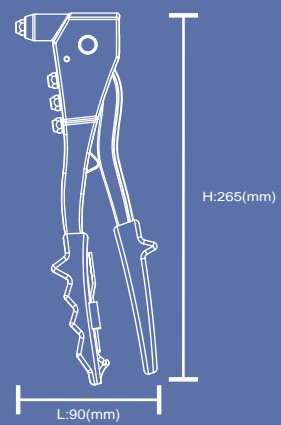

WEIGHT:0.56kg
(TOOL ONLY)

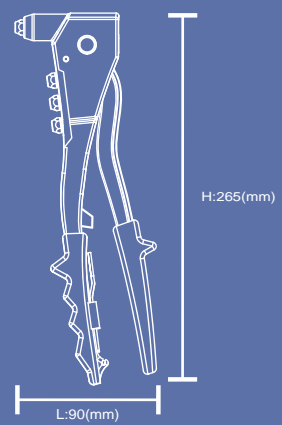

WEIGHT:0.56kg
(TOOL ONLY)

TC701

J701

J705

For FASTENER TYPE



BODY MATERIAL

ALUMINUM

LEVER MATERIAL

STEEL

RIVET RANGE

2.4-4.8mm(3/32"-3/16")



All steel and aluminum construction.



Strong aluminum body frame.



TC702 TC722 GN71

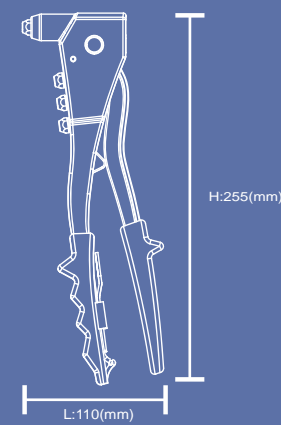

WEIGHT:0.56kg
(TOOL ONLY)

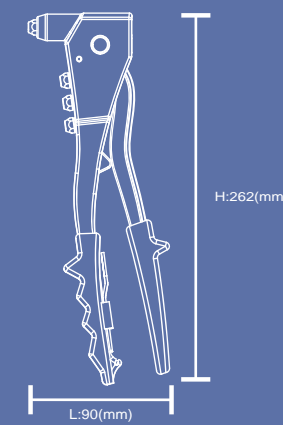

WEIGHT:0.59kg
(TOOL ONLY)

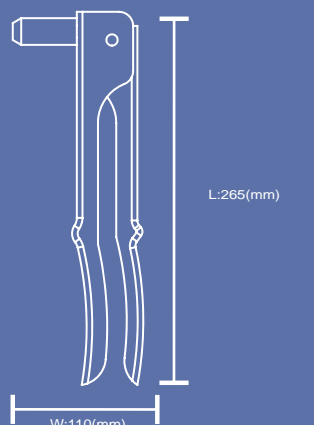

WEIGHT:0.61 kg
(TOOL ONLY)

TC702

TC722

GN71

For FASTENER TYPE



BODY MATERIAL

ALUMINUM

LEVER MATERIAL

STEEL

RIVET RANGE

2.4-4.8mm(3/32"-3/16")

Rivet Nut Fastening Tool

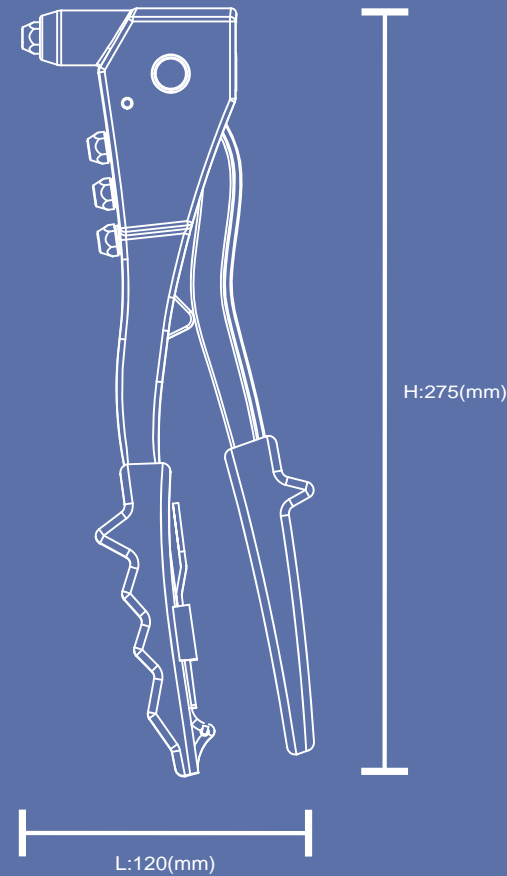

WEIGHT:0.58kg
(TOOL ONLY)

N701

N701

For FASTENER
TYPE



BODY MATERIAL

ALUMINUM

LEVER MATERIAL

STEEL



M3-M6(1/8"-1/4")



All steel and aluminum construction.



Easy to change mandrels.

Hollow Wall Anchor And Plastic Rivet Fastening Tool



TC704 TC705

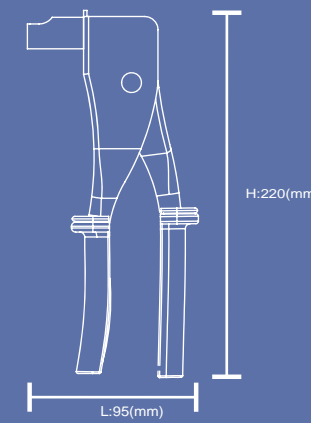

WEIGHT:0.47kg
(TOOL ONLY)

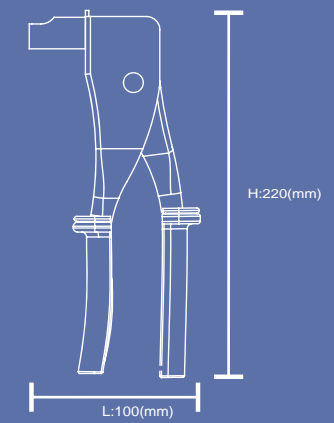

WEIGHT:0.50kg
(TOOL ONLY)

	TC704	TC705
For FASTENER TYPE		
BODY MATERIAL	STEEL	STEEL
LEVER MATERIAL	STEEL	STEEL

OPTIONS

SUITABLE MODELS



All black TPR grip

H1	HF101	HF151	TC101	TC151
H2	HF102	HF152	TC102	TC152
H3	HF103	HF153	TC103	TC153
H4	HF104	HF154	TC104	TC154
H7	HF107	HF157	TC107	TC157

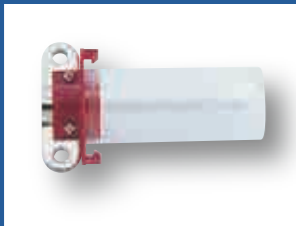

Mandrel Collector

H1	HF101	HF151	TC101	TC151
H3	HF103	HF153	TC103	TC153
H7	HF107	HF157	TC107	TC157



Measurement Gauge

H2	HF102	HF152	TC102	TC152
H4	HF104	HF154	TC104	TC154

